



# **DEEP SEA ELECTRONICS**

## **DSE3110 Operator Manual**

**Document Number: 057-086**

Author: Ashley Senior





**Deep Sea Electronics Ltd.**

Highfield House  
Hunmanby  
North Yorkshire  
YO14 0PH  
England

**Sales Tel:** +44 (0) 1723 890099

**E-mail:** [sales@deepseaelectronics.com](mailto:sales@deepseaelectronics.com)

**Website:** [www.deepseaelectronics.com](http://www.deepseaelectronics.com)

**DSE3110 Operator Manual**

© Deep Sea Electronics Ltd.

All rights reserved. No part of this publication may be reproduced in any material form (including photocopying or storing in any medium by electronic means or other) without the written permission of the copyright holder except in accordance with the provisions of the Copyright, Designs and Patents Act 1988.

Applications for the copyright holder's written permission to reproduce any part of this publication must be addressed to Deep Sea Electronics Ltd. at the address above.

The DSE logo and the names DSEGenset<sup>®</sup>, DSEATS<sup>®</sup>, DSEPower<sup>®</sup> and DSEControl<sup>®</sup> are UK registered trademarks of Deep Sea Electronics Ltd.

Any reference to trademarked product names used within this publication is owned by their respective companies.

Deep Sea Electronics Ltd. reserves the right to change the contents of this document without prior notice.

**Amendments Since Last Publication**

Issue	Comments
2	Update to Typical wiring diagram and Power supply requirements
2.1	Corrected part numbers for ordering spare connectors.
2.2	Removal of incorrect inclusion of Clock/Scheduler function – not available in 3000 series.
3	Addition of phase to phase voltage, AC systems and oil pressure as PSI
5	Changes to input wetting current and current consumption of supply.
6	Updated style of document

Typeface: The typeface used in this document is Arial. Care must be taken not to mistake the upper case letter I with the numeral 1. The numeral 1 has a top serif to avoid this confusion.

## TABLE OF CONTENTS

SECTION	PAGE
<b>1 INTRODUCTION.....</b>	<b>6</b>
<b>1.1 CLARIFICATION OF NOTATION.....</b>	<b>7</b>
<b>1.2 GLOSSARY OF TERMS .....</b>	<b>7</b>
<b>1.3 BIBLIOGRAPHY .....</b>	<b>8</b>
1.3.1 INSTALLATION INSTRUCTIONS .....	8
1.3.2 MANUALS.....	8
1.3.3 TRAINING GUIDES.....	8
1.3.4 THIRD PARTY DOCUMENTS .....	8
<b>2 SPECIFICATIONS .....</b>	<b>9</b>
<b>2.1 PART NUMBERING.....</b>	<b>9</b>
<b>2.2 OPERATING TEMPERATURE.....</b>	<b>9</b>
<b>2.3 REQUIREMENTS FOR UL CERTIFICATION .....</b>	<b>9</b>
<b>2.4 TERMINAL SPECIFICATION.....</b>	<b>10</b>
<b>2.5 POWER SUPPLY REQUIREMENTS.....</b>	<b>10</b>
2.5.1 MODULE SUPPLY INSTRUMENTATION DISPLAY .....	10
<b>2.6 GENERATOR VOLTAGE &amp; FREQUENCY SENSING.....</b>	<b>11</b>
<b>2.7 INPUTS.....</b>	<b>11</b>
2.7.1 DIGITAL INPUTS.....	11
2.7.2 CHARGER ALTERNATOR FAIL.....	11
2.7.3 MAGNETIC PICK-UP .....	12
<b>2.8 OUTPUTS.....</b>	<b>12</b>
2.8.1 DC OUTPUTS A & B (FUEL & START).....	12
2.8.2 CONFIGURABLE DC OUTPUTS C AND D.....	12
<b>2.9 COMMUNICATION PORTS .....</b>	<b>12</b>
2.9.1 COMMUNICATION PORT USAGE.....	13
2.9.1.1 USB CONNECTION (PC CONFIGURATION).....	13
2.9.1.2 CAN PORT (J1939).....	14
<b>2.10 ACCUMULATED INSTRUMENTATION.....</b>	<b>14</b>
<b>2.11 DIMENSIONS AND MOUNTING.....</b>	<b>15</b>
2.11.1 DIMENSIONS.....	15
2.11.2 PANEL CUTOUT.....	15
2.11.3 WEIGHT.....	15
2.11.4 FIXING CLIPS .....	16
2.11.5 SILICON SEALING GASKET.....	17
<b>2.12 APPLICABLE STANDARDS .....</b>	<b>18</b>
2.12.1 ENCLOSURE CLASSIFICATIONS .....	20
2.12.1.1 IP CLASSIFICATIONS.....	20
2.12.1.2 NEMA CLASSIFICATIONS.....	20
<b>3 INSTALLATION.....</b>	<b>21</b>
<b>3.1 USER CONNECTIONS .....</b>	<b>21</b>
<b>3.2 CONNECTION DESCRIPTIONS .....</b>	<b>22</b>
3.2.1 DC SUPPLY, DC OUTPUTS A TO D & CHARGE FAIL INPUT .....	22
3.2.2 GENERATOR VOLTAGE & FREQUENCY SENSING.....	22
3.2.3 MAGNETIC PICK-UP AND DIGITAL INPUTS (3110-XXX-01).....	23
3.2.4 CAN AND DIGITAL INPUTS (3110-XXX-02).....	23
3.2.5 PC CONFIGURATION INTERFACE CONNECTOR.....	24
<b>3.3 TYPICAL WIRING DIAGRAM .....</b>	<b>25</b>
3.3.1 EARTH SYSTEMS .....	26
3.3.1.1 NEGATIVE EARTH.....	26
3.3.1.2 POSITIVE EARTH.....	26
3.3.1.3 FLOATING EARTH.....	26
<b>4 DESCRIPTION OF CONTROLS.....</b>	<b>27</b>
<b>4.1 CONTROL PUSH-BUTTONS.....</b>	<b>28</b>
<b>4.2 MODULE DISPLAY.....</b>	<b>29</b>

4.2.1	BACKLIGHT .....	29
4.2.2	ICON .....	29
4.2.2.1	INOPERABLE ICONS .....	29
4.2.2.2	MODE ICON .....	29
4.2.2.3	ALARM ICONS (PROTECTIONS) .....	30
4.2.3	VIEWING THE INSTRUMENT PAGES .....	33
<b>5</b>	<b>OPERATION .....</b>	<b>34</b>
<b>5.1</b>	<b>QUICKSTART GUIDE .....</b>	<b>34</b>
5.1.1	STARTING THE ENGINE .....	34
5.1.2	STOPPING THE ENGINE .....	35
<b>5.2</b>	<b>STOP/RESET MODE .....</b>	<b>36</b>
<b>5.3</b>	<b>AUTOMATIC MODE .....</b>	<b>37</b>
5.3.1	WAITING IN AUTO MODE .....	37
5.3.2	STARTING SEQUENCE .....	37
5.3.3	ENGINE RUNNING .....	38
5.3.4	STOPPING SEQUENCE .....	38
<b>5.4</b>	<b>MANUAL/START MODE .....</b>	<b>39</b>
5.4.1	WAITING IN MANUAL MODE .....	39
5.4.2	STARTING SEQUENCE .....	40
5.4.3	ENGINE RUNNING .....	40
5.4.4	STOPPING SEQUENCE .....	41
<b>5.5</b>	<b>ALTERNATIVE CONFIGURATIONS .....</b>	<b>41</b>
<b>6</b>	<b>FRONT PANEL CONFIGURATION .....</b>	<b>42</b>
<b>6.1</b>	<b>ACCESSING &amp; OPERATING THE FRONT PANEL EDITORS .....</b>	<b>43</b>
6.1.1	ENTERING THE EDITORS .....	43
6.1.2	EDITING A PARAMETER .....	43
6.1.3	EXITING THE EDITORS .....	43
<b>6.2</b>	<b>ADJUSTABLE PARAMETERS IN CONFIGURATION EDITOR .....</b>	<b>44</b>
6.2.1	MODULE SETTINGS .....	44
6.2.2	CAN SETTINGS .....	44
6.2.3	DIGITAL INPUT SETTINGS .....	45
6.2.4	OUTPUT SETTINGS .....	45
6.2.5	TIMER SETTINGS .....	46
6.2.6	GENERATOR SETTINGS .....	46
6.2.7	ENGINE SETTINGS .....	47
6.2.8	ALTERNATE CONFIGURATION SETTINGS .....	47
<b>6.3</b>	<b>SELECTABLE PARAMETER SETTINGS .....</b>	<b>48</b>
6.3.1	OUTPUT SOURCES .....	48
6.3.2	INPUT SOURCES .....	49
6.3.3	AC TOPOLOGY .....	49
6.3.4	ALARM ACTION .....	49
6.3.5	DIGITAL INPUT ALARM ARMING .....	49
6.3.6	DIGITAL INPUT POLARITY .....	49
6.3.7	DIGITAL OUTPUT POLARITY .....	50
6.3.8	CAN DATA FAIL ALARM ACTION .....	50
6.3.9	CAN DATA FAIL ALARM ARMING .....	50
<b>7</b>	<b>COMMISSIONING .....</b>	<b>51</b>
<b>8</b>	<b>FAULT FINDING .....</b>	<b>52</b>
<b>8.1</b>	<b>STARTING .....</b>	<b>52</b>
<b>8.2</b>	<b>LOADING .....</b>	<b>52</b>
<b>8.3</b>	<b>ALARMS .....</b>	<b>53</b>
<b>8.4</b>	<b>COMMUNICATIONS .....</b>	<b>53</b>
<b>8.5</b>	<b>MISCELLANEOUS .....</b>	<b>53</b>
<b>9</b>	<b>MAINTENANCE, SPARES, REPAIR AND SERVICING .....</b>	<b>54</b>
<b>9.1</b>	<b>PURCHASING ADDITIONAL CONNECTOR PLUGS FROM DSE .....</b>	<b>54</b>
9.1.1	PACK OF PLUGS .....	54
9.1.2	INDIVIDUAL PLUGS .....	54

9.2	PURCHASING ADDITIONAL FIXING CLIPS FROM DSE .....	54
9.3	PURCHASING OPTIONAL SEALING GASKET FROM DSE .....	54
10	WARRANTY .....	55
11	DISPOSAL .....	55
11.1	WEEE (WASTE ELECTRICAL AND ELECTRONIC EQUIPMENT).....	55

## 1 INTRODUCTION

This document details the installation and operation requirements of the DSE3110 module.

The manual forms part of the product and must be kept for the entire life of the product. If the product is passed or supplied to another party, ensure that this document is passed to them for reference purposes.

This is not a *controlled document*. Updates are not automatically informed. Any future updates of this document are included on the DSE website at [www.deepseaelectronics.com](http://www.deepseaelectronics.com)

The DSE3xxx series is designed to provide differing levels of functionality across a common platform. This allows the generator OEM greater flexibility in the choice of controller to use for a specific application.

The DSE3110 module has been designed to allow the operator to start and stop the generator, and if required, transfer the load to the generator either manually or automatically.

The powerful ARM microprocessor contained within the module allows for incorporation of a range of complex features:

- *Icon based LCD display*
- *True RMS Voltage monitoring*
- *USB Communications*
- *Engine parameter monitoring.*
- *Fully configurable inputs for use as alarms or a range of different functions.*
- *Engine ECU interface to electronic engines (specify on ordering)*
- *Magnetic pickup interface for engine only applications (specify on ordering)*

Using a PC and the DSE Configuration Suite software allows alteration of selected operational sequences, timers, alarms and operational sequences. Additionally, the module's integral front panel configuration editor allows adjustment of this information.



A robust plastic case designed for front panel mounting houses the module. Connections are via locking plug and sockets.

Access to critical operational sequences and timers for use by qualified engineers can be changed from the module's front panel.

The module is housed in a robust plastic case suitable for panel mounting. Connections to the module are via locking plug and sockets.

## 1.1 CLARIFICATION OF NOTATION

Clarification of notation used within this publication.

 <b>NOTE:</b>	Highlights an essential element of a procedure to ensure correctness.
 <b>CAUTION!</b>	Indicates a procedure or practice, which, if not strictly observed, could result in damage or destruction of equipment.
 <b>WARNING!</b>	Indicates a procedure or practice, which could result in injury to personnel or loss of life if not followed correctly.

## 1.2 GLOSSARY OF TERMS

Term	Description
DSE3xxx	All modules in the DSE3xxx range.
DSE3110 MPU	DSE3110 module/controller that senses engine speed using an MPU sensor or alternator frequency
DSE3110 CAN	DSE3110 module/controller that senses engine speed from the CAN connection.
CAN	Controller Area Network Vehicle standard to allow digital devices to communicate to one another.
DM1	Diagnostic Message 1 A DTC that is currently active on the engine ECU.
DTC	Diagnostic Trouble Code The name for the entire fault code sent by an engine ECU.
ECU/ECM	Engine Control Unit/Management An electronic device that monitors engine parameters and regulates the fuelling.
FMI	Failure Mode Indicator A part of DTC that indicates the type of failure, e.g. high, low, open circuit etc.
MPU	Magnetic Pick-Up A sensor that measures an engine's speed by detecting movement of the flywheel's teeth.
OC	Occurrence Count A part of DTC that indicates the number of times that failure has occurred.
PGN	Parameter Group Number A CAN address for a set of parameters that relate to the same topic and share the same transmission rate.
PLC	Programmable Logic Controller A programmable digital device used to create logic for a specific purpose.
SPN	Suspect Parameter Number A part of DTC that indicates what the failure is, e.g. oil pressure, coolant temperature, turbo pressure etc.

### 1.3 BIBLIOGRAPHY

This document refers to, and is referred by the following DSE publications which are obtained from the DSE website: [www.deepseaelectronics.com](http://www.deepseaelectronics.com) or by contacting DSE technical support: [support@deepseaelectronics.com](mailto:support@deepseaelectronics.com).

#### 1.3.1 INSTALLATION INSTRUCTIONS

Installation instructions are supplied with the product in the box and are intended as a 'quick start' guide only.

DSE Part	Description
053-050	DSE3110 Installation Instructions

#### 1.3.2 MANUALS

Product manuals are obtained from the DSE website: [www.deepseaelectronics.com](http://www.deepseaelectronics.com) or by contacting DSE technical support: [support@deepseaelectronics.com](mailto:support@deepseaelectronics.com).

DSE Part	Description
057-004	Electronic Engines and DSE Wiring Guide
057-151	DSE Configuration Suite PC Software Installation & Operation Manual
057-087	DSE3110 Configuration Suite PC Software Manual

#### 1.3.3 TRAINING GUIDES

Training guides are provided as 'hand-out' sheets on specific subjects during training sessions and contain specific information regarding to that subject.

DSE Part	Description
056-022	Switchgear Control
056-023	Adding New CAN Files
056-029	Smoke Limiting
056-055	Alternate Configurations
056-069	Firmware Update
056-091	Equipotential Earth Bonding
056-092	Recommended Practices for Wiring Resistive Sensors
056-095	Remote Start Input Functions
056-097	USB Earth Loops and Isolation

#### 1.3.4 THIRD PARTY DOCUMENTS

The following third party documents are also referred to:

Reference	Description
ISBN 1-55937-879-4	IEEE Std C37.2-1996 IEEE Standard Electrical Power System Device Function Numbers and Contact Designations. Institute of Electrical and Electronics Engineers Inc
ISBN 0-7506-1147-2	Diesel generator handbook. L.L.J.Mahon
ISBN 0-9625949-3-8	On-Site Power Generation. EGSA Education Committee.



## 2 SPECIFICATIONS

### 2.1 PART NUMBERING

At the time of this document production, there are two variants of this product.

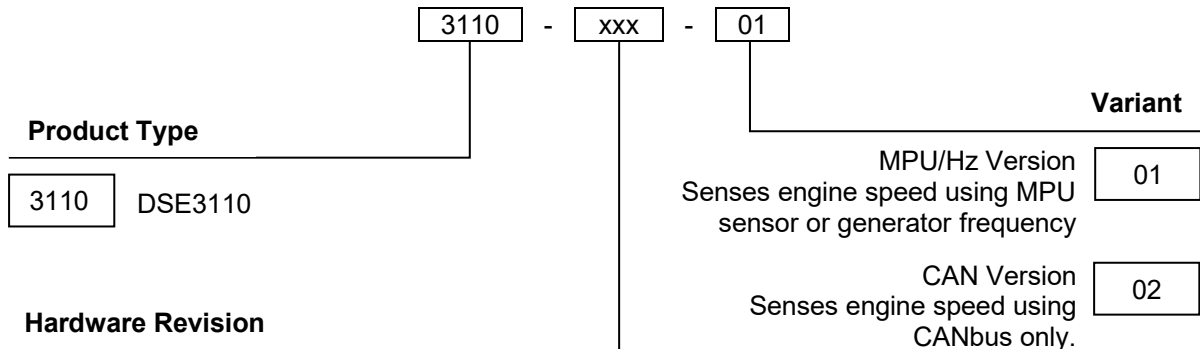

### 2.2 OPERATING TEMPERATURE

Module	Specification
DSE3110	-30 °C +70 °C (-22 °F +158 °F)

### 2.3 REQUIREMENTS FOR UL CERTIFICATION

 **WARNING!** More than one live circuit exists, refer to section entitled *Typical Wiring Diagram* elsewhere in this document

Description	Specification
Screw Terminal Tightening Torque	4.5 lb-in (0.5 Nm)
Conductors	<ul style="list-style-type: none"> <li>Terminals suitable for connection of conductor size 13 AWG to 20 AWG (0.5 mm<sup>2</sup> to 2.5 mm<sup>2</sup>).</li> <li>Conductor protection must be provided in accordance with NFPA 70, Article 240</li> <li>Low voltage circuits (35 V or less) must be supplied from the engine starting battery or an isolated secondary circuit.</li> <li>The communication, sensor, and/or battery derived circuit conductors shall be separated and secured to maintain at least ¼" (6 mm) separation from the generator and mains connected circuit conductors unless all conductors are rated 600 V or greater.</li> </ul>
Communication Circuits	Must be connected to communication circuits of UL Listed equipment
Output Pilot Duty	0.5 A
Mounting	<ul style="list-style-type: none"> <li>Suitable for use in type 1 Enclosure Type rating with surrounding air temperature -22 °F to +158 °F (-30 °C to +70 °C)</li> <li>Suitable for pollution degree 3 environments when voltage sensing inputs do not exceed 300 V. When used to monitor voltages over 300 V device to be installed in an unventilated or filtered ventilation enclosure to maintain a pollution degree 2 environment.</li> </ul>
Operating Temperature	-22 °F to +158 °F (-30 °C to +70 °C)
Storage Temperature	-40 °F to +176 °F (-40 °C to +80 °C)

## 2.4 TERMINAL SPECIFICATION

**NOTE:** For purchasing additional connector plugs from DSE, see the section entitled **Maintenance, Spares, Repair and Servicing** elsewhere in this document.

Description	Specification	
Connection Type	Two part connector. Male part fitted to module Female part supplied in module packing case - Screw terminal, rising clamp, no internal spring.	 <p>Example showing cable entry and screw terminals of a 10 way connector</p>
Minimum Cable Size	0.5 mm <sup>2</sup> (AWG 20)	
Maximum Cable Size	2.5 mm <sup>2</sup> (AWG 13)	
Tightening Torque	0.5 Nm (4.5 lb-in)	
Wire Strip Length	7 mm (9/32")	

## 2.5 POWER SUPPLY REQUIREMENTS

Description	Specification
Minimum Supply Voltage	8 V continuous
Cranking Dropouts	Able to survive 0 V for 50 ms providing the supply was at least 10 V before the dropout and recovers to 5 V afterwards.
Maximum Supply Voltage	35 V continuous (60 V protection)
Reverse Polarity Protection	-35 V continuous
Maximum Operating Current 3110-001-xx to 3110-005-xx	35 mA at 12 V 33 mA at 24 V
Maximum Operating Current 3110-006-xx onwards	76 mA at 12 V 61 mA at 24 V
Nominal Standby Current 3110-001-xx to 3110-005-xx	23 mA at 12 V 18 mA at 24 V
Nominal Standby Current 3110-006-xx onwards	45 mA at 12 V 43 mA at 24 V
Maximum Current When In Sleep Mode	3.5 mA at 12 V 3.5 mA at 24 V

### 2.5.1 MODULE SUPPLY INSTRUMENTATION DISPLAY

Description	Specification
Range	0 V to 70 V DC Maximum continuous operating voltage of 35 V DC
Resolution	0.1 V
Accuracy	1% full scale ( $\pm 0.7$ V)

## 2.6 GENERATOR VOLTAGE & FREQUENCY SENSING

Description	Specification
Measurement Type	True RMS conversion
Sample Rate	5 kHz or better
Harmonics	Up to 11 <sup>th</sup>
Input Impedance	300 k $\Omega$ phase to neutral
Phase To Neutral	15 V (minimum required for sensing frequency) to 333 V AC (absolute maximum) Suitable for 230 V nominal ( $\pm 20$ % for under/overvoltage detection)
Common Mode Offset From Earth	100 V AC (max)
Resolution	1 V AC phase to neutral
Accuracy	$\pm 1$ % of full scale phase to neutral
Minimum Frequency	3.5 Hz
Maximum Frequency	75.0 Hz
Frequency Resolution	0.1 Hz
Frequency Accuracy	$\pm 0.2$ Hz

## 2.7 INPUTS

### 2.7.1 DIGITAL INPUTS

Description	Specification
Number	6 configurable digital inputs
Arrangement	Contact between terminal and <i>Power Supply</i> negative terminal.
Low Level Threshold	40 % with respect to <i>Power Supply</i> positive terminal.
High Level Threshold	60 % with respect to <i>Power Supply</i> positive terminal.
Maximum Input Voltage	+60 V DC with respect to <i>Power Supply</i> negative terminal.
Minimum Input Voltage	-35 V DC with respect to <i>Power Supply</i> negative terminal.
Contact Wetting Current	5 mA typical
Open Circuit Voltage	<i>Power Supply</i> positive voltage

### 2.7.2 CHARGER ALTERNATOR FAIL

The charge fail input is a combined input and output. Whenever the generator is required to run, the terminal provides excitation current to the charge alternator field winding.

When the charge alternator is correctly charging the battery, the voltage of the terminal is close to the plant battery supply voltage. In a failed charge situation, the voltage of this terminal is pulled down to a low voltage. It is this drop in voltage that triggers the *charge failure* alarm. The level at which this operates and whether this triggers a warning or shutdown alarm is configurable using the DSE Configuration Suite Software.

Description	Specification
Minimum Voltage	0 V
Maximum Voltage	60 V
Resolution	0.2 V
Accuracy	$\pm 1$ % of max measured voltage
Excitation	Active circuit constant power output
Output Power	2.5 W $\pm 10$ % nominal at 12 V and 24 V
Current At 12 V	210 mA
Current At 24 V	105 mA

### 2.7.3 MAGNETIC PICK-UP

 **NOTE: Only applicable to 3110-xxx-01 MPU/Hz variant.**

Magnetic Pickup devices can often be 'shared' between two or more devices. For example, one device can often supply the signal to both the DSE module and the engine governor. The possibility of this depends upon the amount of current that the magnetic pickup can supply.

Description	Specification
Type	Single ended input, capacitive coupled
Minimum Voltage	0.5 V peak
Maximum Voltage	70 V peak
Max Common Mode Voltage	±2 V peak
Minimum Frequency	5 Hz
Maximum Frequency	10,000 Hz
Resolution	6.25 rpm
Accuracy	± 25 rpm
Flywheel Teeth	10 to 500

## 2.8 OUTPUTS

There are four outputs fitted to the controller

### 2.8.1 DC OUTPUTS A & B (FUEL & START)

 **NOTE: DC outputs A and B are fixed to Fuel and Start for the 3110-xxx-01 MPU/Hz variant, they are only configurable with the 3110-xxx-02 CAN variant.**

Description	Specification
Type	Supplied from <i>Power Supply</i> positive terminal.
Rating	2 A resistive continuous at 35 V

### 2.8.2 CONFIGURABLE DC OUTPUTS C AND D

Description	Specification
Type	Fully configurable, supplied from <i>Power Supply</i> positive terminal.
Rating	2 A resistive continuous at 35 V

## 2.9 COMMUNICATION PORTS

Description	Specification
USB Port	USB 2.0 Device for connection to PC running DSE configuration suite only. Max distance 6 m (18 yards)
CAN Port	 <b>NOTE: Only applicable to 3110-xxx-02 CAN variant.</b>
	Engine CAN Port Standard implementation of 'Slow mode', up to 250 kb/s. Non-Isolated. Internal Termination provided (120 Ω) Max distance 40 m (133 feet)

## 2.9.1 COMMUNICATION PORT USAGE

### 2.9.1.1 USB CONNECTION (PC CONFIGURATION)

**NOTE:** DSE stock 2 m (6.5 feet) USB type A to type B cable, DSE Part Number: 016-125. Alternatively, they are purchased from any PC or IT store.

**NOTE:** The DC supply must be connected to the module for configuration by PC.

**NOTE:** For further details of module configuration, refer to DSE Publication: 057-087 *DSE3110 DSE Configuration Suite PC Software Manual*.

The USB port is provided to give a simple means of connection between a PC and the controller. Using the DSE Configuration Suite Software, the operator is then able to control the module, starting or stopping the generator, selecting operating modes, etc.

Additionally, the various operating parameters (such as output volts, oil pressure, etc.) of the remote generator are available to be viewed or changed.

To connect a module to a PC by USB, the following items are required:

- DSE3110 Controller
- DSE Configuration Suite PC Software  
(Available from [www.deepseaelectronics.com](http://www.deepseaelectronics.com)).
- USB cable Type A to Type B.  
(This is the same cable as often used between a PC and a USB printer)  
DSE stock this cable:  
PC Configuration interface lead (USB type A – type B) DSE  
Part No 016-125

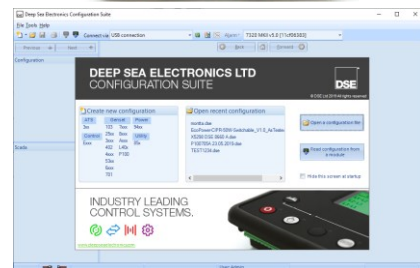

2.9.1.2 CAN PORT (J1939)

**NOTE:** Only applicable to 3110-xxx-02 CAN variant.

**NOTE:** For further details of module configuration, refer to DSE Publication: *057-087 DSE3110 DSE Configuration Suite PC Software Manual*.

**NOTE:** For further details on connection to electronic engines, refer to DSE Publication: *057-004 Electronic Engines And DSE Wiring*

**NOTE:** Screened 120 Ω impedance cable specified for use with CAN must be used for the CAN link.  
DSE stock and supply Belden cable 9841 which is a high quality 120 Ω impedance cable suitable for CAN use (DSE part number 016-030)

**NOTE:** For additional length, the DSE124 CAN & MSC Extender is available. For more information, refer to DSE Publication: *057-116 DSE124 Operator Manual*

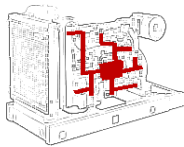

The modules are fitted with a CAN interface as standard and are capable of receiving engine data from engine ECU/ECMs compliant with the CAN J1939 standard.

ECU/ECMs monitor the engine's operating parameters such as speed, oil pressure, coolant temperature (among others) in order to closely monitor and control the engine. The industry standard communications interface (CAN) transports data gathered by the engine's ECU/ECM using the J1939 protocol. This allows engine controllers such as DSE to access these engine parameters with no physical connection to the sensor device.

The *ECU Port* is used for point-to-point cable connection of more than one device and allows for connection to CAN Scanner, PLC and CAN controllers (to name just a few devices). The operator is then able to view the various operating parameters.

2.10 ACCUMULATED INSTRUMENTATION

**NOTE:** When an accumulated instrumentation value exceeds the maximum number as listed below, the value is reset and begins counting from zero again.

The number of logged *Engine Hours* and *Number of Starts* can be set/reset using the DSE Configuration Suite PC software. Depending upon module configuration, this may have been PIN number locked by the generator supplier.

Description	Specification
Engine Hours Run	Maximum 99999 hrs 59 minutes (Approximately 11yrs 4 months)
Number of Starts	1,000,000 (1 Million)

## 2.11 DIMENSIONS AND MOUNTING

### 2.11.1 DIMENSIONS

99 mm x 79 mm x 41.5 mm  
(3.90 " x 3.11 " x 1.63 ")

### 2.11.2 PANEL CUTOUT

80 mm x 68 mm  
(3.15 " x 2.86 ")

### 2.11.3 WEIGHT

0.09 kg  
(0.20 lb)

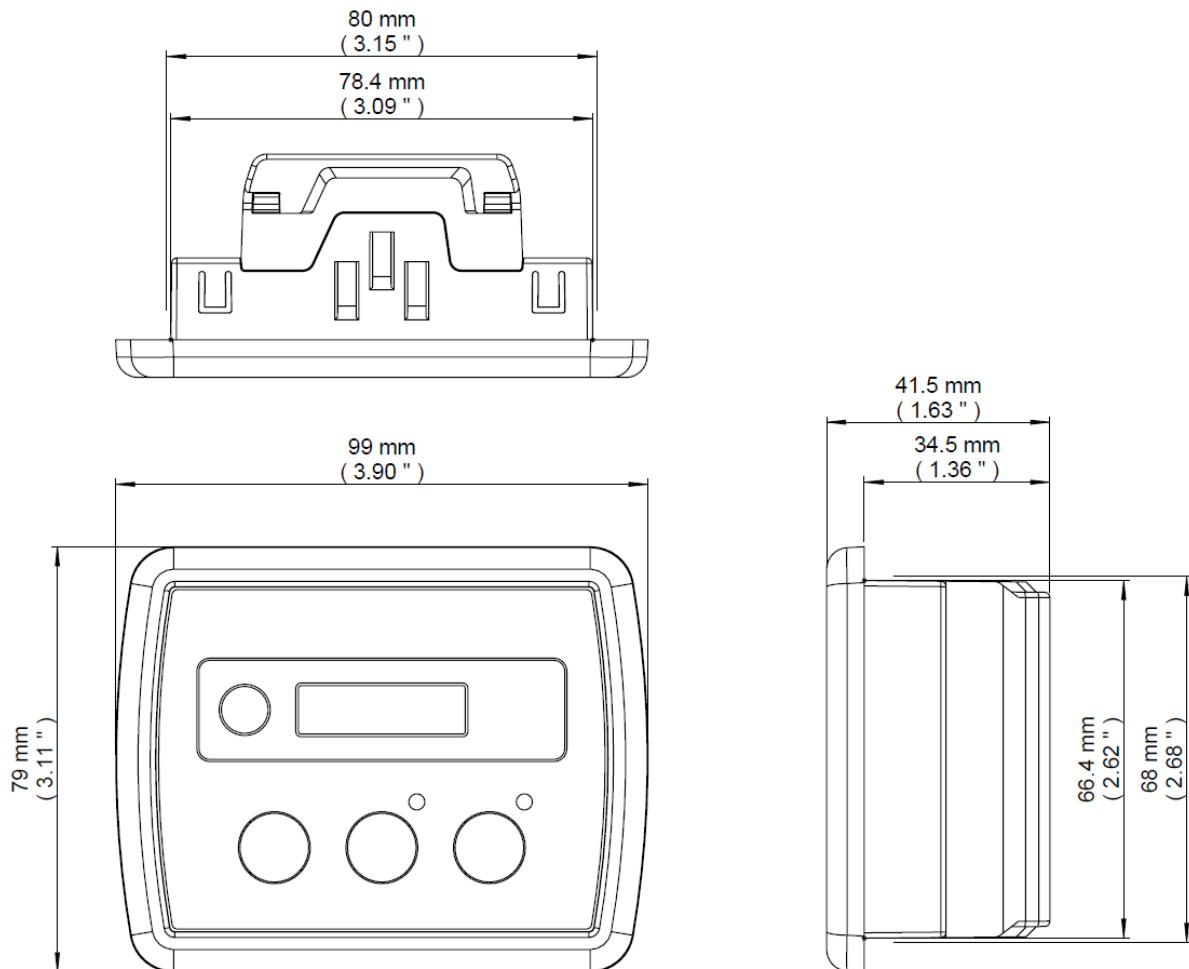

#### 2.11.4 FIXING CLIPS

**NOTE:** In conditions of excessive vibration, mount the module on suitable anti-vibration mountings.

The module is held into the panel fascia using the supplied fixing clips.

- Withdraw the fixing clip screw (turn anticlockwise) until only the pointed end is protruding from the clip.
- Insert the three 'prongs' of the fixing clip into the slots in the side of the module case.
- Pull the fixing clip backwards (towards the back of the module) ensuring all three prongs of the clip are inside their allotted slots.
- Turn the fixing clip screws clockwise until they make contact with the panel fascia.
- Turn the screw a quarter of a turn to secure the module into the panel fascia. Care must be taken not to over tighten the fixing clip screws

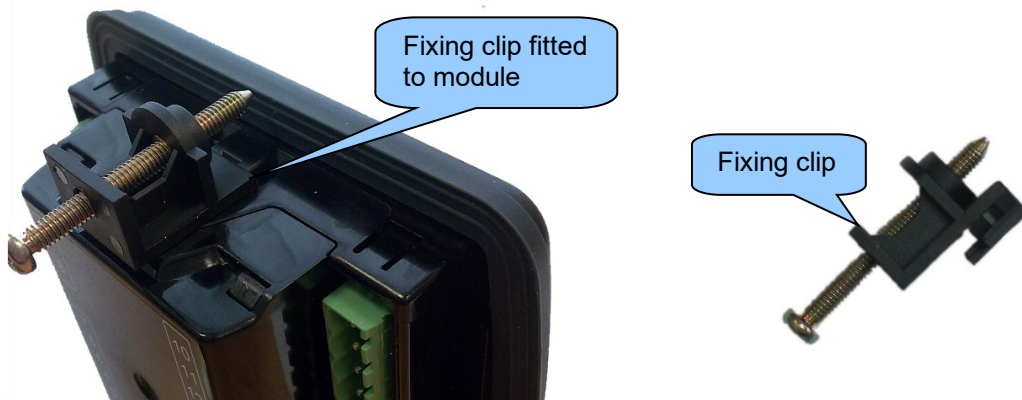



### 2.11.5 OPTIONAL SILICON SEALING GASKET

**▲ NOTE:** For purchasing an additional silicon gasket from DSE, see the section entitled **Maintenance, Spares, Repair and Servicing elsewhere in this document.**

The optional silicon gasket provides improved sealing between module and the panel fascia. The gasket is fitted to the module before installation into the panel fascia. Take care to ensure the gasket is correctly fitted to the module to maintain the integrity of the seal.

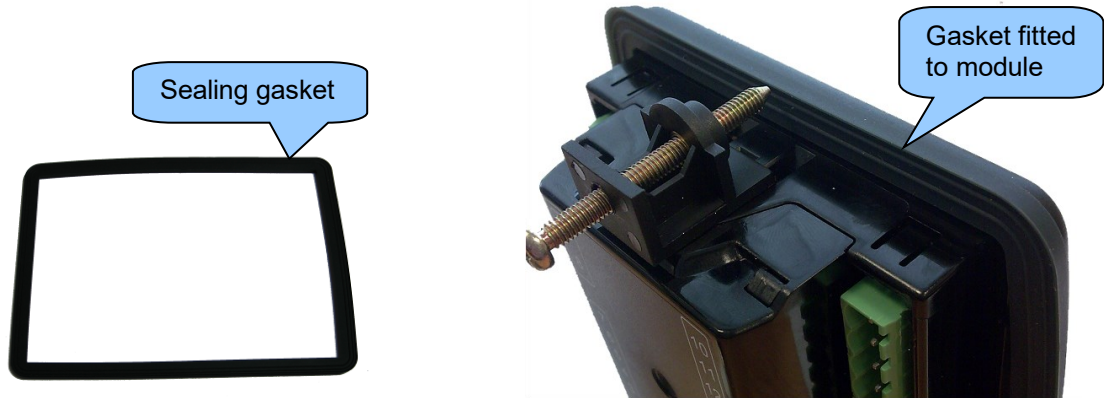

## 2.12 APPLICABLE STANDARDS

Standard	Description
<b>BS 4884-1</b>	This document conforms to BS4884-1 1992 Specification for presentation of essential information.
<b>BS 4884-2</b>	This document conforms to BS4884-2 1993 Guide to content
<b>BS 4884-3</b>	This document conforms to BS4884-3 1993 Guide to presentation
<b>BS EN 60068-2-1</b> (Minimum temperature)	-30 °C (-22 °F)
<b>BS EN 60068-2-2</b> (Maximum temperature)	+70 °C (158 °F)
<b>BS EN 60068-2-6</b> (Vibration)	Ten sweeps in each of three major axes 5 Hz to 8 Hz at ± 7.5 mm 8 Hz to 500 Hz at 2 gn
<b>BS EN 60068-2-27</b> (Shock)	Three shocks in each of three major axes 15 gn in 11 ms
<b>BS EN 60068-2-30</b> (Damp heat cyclic)	20 °C to 55 °C at 95% relative humidity for 48 hours
<b>BS EN 60068-2-78</b> (Damp heat static)	40 °C at 95% relative humidity for 48 hours
<b>BS EN 60950</b> (Electrical safety)	Safety of information technology equipment, including electrical business equipment
<b>BS EN 61000-6-2</b> (Electro-magnetic Compatibility)	EMC Generic Immunity Standard (Industrial)
<b>BS EN 61000-6-4</b> (Electro-magnetic Compatibility)	EMC Generic Emission Standard (Industrial)
<b>BS EN 60529</b> (Degrees of protection provided by enclosures)	IP65 (front of module when installed into the control panel with the optional sealing gasket) IP42 (front of module when installed into the control panel WITHOUT being sealed to the panel)
<b>UL 508</b> <b>NEMA rating</b> (Approximate)	12 (Front of module when installed into the control panel with the optional sealing gasket). 2 (Front of module when installed into the control panel WITHOUT being sealed to the panel)
<b>IEEE C37.2</b> (Standard Electrical Power System Device Function Numbers and Contact Designations)	Under the scope of IEEE 37.2, <i>function numbers can also be used to represent functions in microprocessor devices and software programs.</i> The controller is device number 11L-8000 (Multifunction device protecting Line (generator) –module).  As the module is configurable by the generator OEM, the functions covered by the module vary. Under the module's factory configuration, the device numbers included within the module are :  2 – Time Delay Starting Or Closing Relay 5 – Stopping Device 6 – Starting Circuit Breaker 8 – Control Power Disconnecting Device 11 – Multifunction Device 12 – Overspeed Device 14 – Underspeed Device 26 – Apparatus Thermal Device

Continued overleaf...

*Specification*

<b>Standard</b>	<b>Description</b>
<b>IEEE C37.2</b> (Standard Electrical Power System Device Function Numbers and Contact Designations)	Continued...  27DC – DC Undervoltage Relay 29 – Isolating Contactor Or Switch 30 – Annunciator Relay 42 – Running Circuit Breaker 52 – AC Circuit Breaker 54 – Turning Gear Engaging Device 59AC – AC Overvoltage Relay 62 – Time Delay Stopping Or Opening Relay 63 – Pressure Switch 71 – Level Switch 74 – Alarm Relay 81 – Frequency Relay 86 – Lockout Relay

In line with our policy of continual development, Deep Sea Electronics, reserve the right to change specification without notice.

## 2.12.1 ENCLOSURE CLASSIFICATIONS

### 2.12.1.1 IP CLASSIFICATIONS

The modules specification under BS EN 60529 Degrees of protection provided by enclosures

**IP65** (Front of module when module is installed into the control panel with the optional sealing gasket).

**IP42** (front of module when module is installed into the control panel WITHOUT being sealed to the panel)

First Digit Protection against contact and ingress of solid objects	Second Digit Protection against ingress of water
0 No protection	0 No protection
1 Protected against ingress solid objects with a diameter of more than 50 mm. No protection against deliberate access, e.g. with a hand, but large surfaces of the body are prevented from approach.	1 Protection against dripping water falling vertically. No harmful effect must be produced (vertically falling drops).
2 Protected against penetration by solid objects with a diameter of more than 12 mm. Fingers or similar objects prevented from approach.	2 Protection against dripping water falling vertically. There must be no harmful effect when the equipment (enclosure) is tilted at an angle up to 15° from its normal position (drops falling at an angle).
3 Protected against ingress of solid objects with a diameter of more than 2.5 mm. Tools, wires etc. with a thickness of more than 2.5 mm are prevented from approach.	3 Protection against water falling at any angle up to 60° from the vertical. There must be no harmful effect (spray water).
4 Protected against ingress of solid objects with a diameter of more than 1 mm. Tools, wires etc. with a thickness of more than 1 mm are prevented from approach.	4 Protection against water splashed against the equipment (enclosure) from any direction. There must be no harmful effect (splashing water).
5 Protected against harmful dust deposits. Ingress of dust is not totally prevented but the dust must not enter in sufficient quantity to interface with satisfactory operation of the equipment. Complete protection against contact.	5 Protection against water projected from a nozzle against the equipment (enclosure) from any direction. There must be no harmful effect (water jet).
6 Protection against ingress of dust (dust tight). Complete protection against contact.	6 Protection against heavy seas or powerful water jets. Water must not enter the equipment (enclosure) in harmful quantities (splashing over).

### 2.12.1.2 NEMA CLASSIFICATIONS

 **NOTE: There is no direct equivalence between IP / NEMA ratings. IP figures shown are approximate only.**

**12** (Front of module when module is installed into the control panel with the optional sealing gasket).

**2** (front of module when module is installed into the control panel WITHOUT being sealed to the panel)

1 <b>IP30</b>	Provides a degree of protection against contact with the enclosure equipment and against a limited amount of falling dirt.
2 <b>IP31</b>	Provides a degree of protection against limited amounts of falling water and dirt.
3 <b>IP64</b>	Provides a degree of protection against windblown dust, rain and sleet; undamaged by the formation of ice on the enclosure.
3R <b>IP32</b>	Provides a degree of protection against rain and sleet;; undamaged by the formation of ice on the enclosure.
4 (X) <b>IP66</b>	Provides a degree of protection against splashing water, windblown dust and rain, hose directed water, undamaged by the formation of ice on the enclosure. (Resist corrosion).
12/12K <b>IP65</b>	Provides a degree of protection against dust, falling dirt and dripping non-corrosive liquids.
13 <b>IP65</b>	Provides a degree of protection against dust and spraying of water, oil and non-corrosive coolants.

### 3 INSTALLATION

The module is designed to be mounted on the panel fascia. For dimension and mounting details, see the section entitled *Specification, Dimension and mounting* elsewhere in this document.

#### 3.1 USER CONNECTIONS

**NOTE:** Availability of some terminals depends upon module version. Full details are given in the section entitled *Terminal Description* elsewhere in this manual.

To aid user connection, numbers are used on the rear of the module to help identify terminal functions. An example of this is shown below.

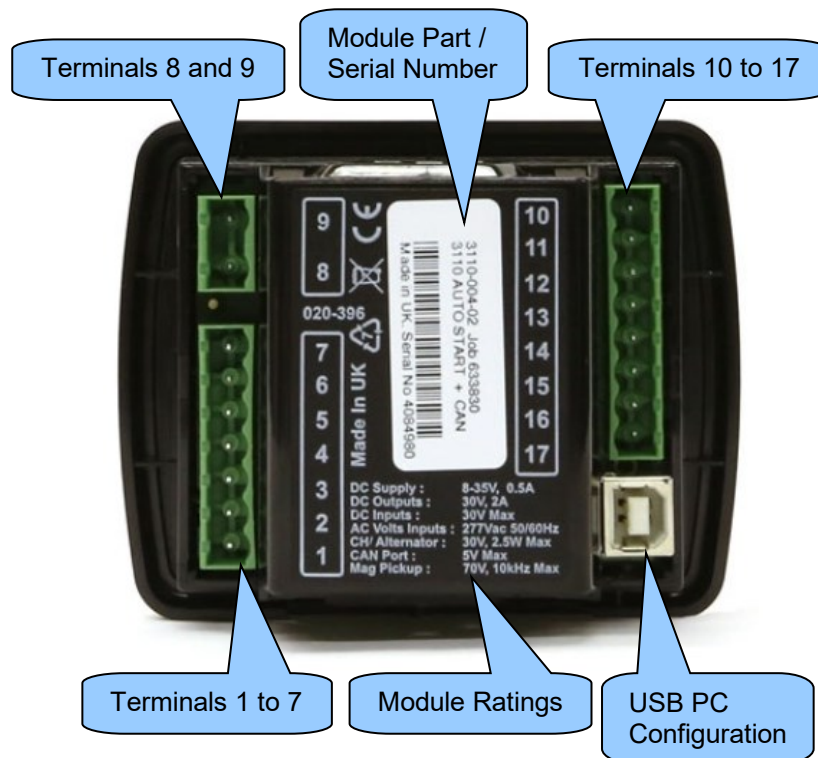

### 3.2 CONNECTION DESCRIPTIONS

#### 3.2.1 DC SUPPLY, DC OUTPUTS A TO D & CHARGE FAIL INPUT

**NOTE:** For further details of module configuration, refer to DSE Publication: *057-087 DSE3110 DSE Configuration Suite PC Software Manual*.

**NOTE:** When the module is configured for operation with an electronic engine, FUEL and START output requirements may be different. For further details on connection to electronic engines, refer to DSE Publication: *057-004 Electronic Engines And DSE Wiring*

Pin No	Description	Cable Size	Notes
1	DC Plant Supply Input (Negative)	2.5 mm <sup>2</sup> AWG 13	
2	DC Plant Supply Input (Positive)	2.5 mm <sup>2</sup> AWG 13	Supplies the module and DC Outputs A, B, C & D
3	DC Output A (FUEL)	2.5 mm <sup>2</sup> AWG 13	Plant Supply Positive from terminal 2. 2 A resistive continuous Fixed as <i>Fuel Relay</i> for 3110-xxx-01 MPU/Hz variant. Configurable for 3110-xxx-02 CAN variant.
4	DC Output B (START)	2.5 mm <sup>2</sup> AWG 13	Plant Supply Positive from terminal 2. 2 A resistive continuous Fixed as <i>Start Relay</i> for 3110-xxx-01 MPU/Hz variant. Configurable for 3110-xxx-02 CAN variant.
5	DC Output C	1.0 mm <sup>2</sup> AWG 18	Plant Supply Positive from terminal 2. 2 Amp rated.
6	DC Output D	1.0 mm <sup>2</sup> AWG 18	Plant Supply Positive from terminal 2. 2 Amp rated.
7	Charge Fail / Excite	2.5 mm <sup>2</sup> AWG 13	Do not connect to ground (battery negative). If charge alternator is not fitted, leave this terminal disconnected.

#### 3.2.2 GENERATOR VOLTAGE & FREQUENCY SENSING

**NOTE:** For further details of module configuration, refer to DSE Publication: *057-087 DSE3110 DSE Configuration Suite PC Software Manual*.

**NOTE:** The below table describes connections to a three phase, four wire alternator. For alternative wiring topologies, see the *Alternate Topology Wiring Diagrams* section of this manual.

Pin No	Description	Cable Size	Notes
8	Generator Neutral (N) Input	1.0 mm <sup>2</sup> AWG 18	Connect to generator neutral terminal.
9	Generator L1 (U) Voltage Input	1.0 mm <sup>2</sup> AWG 18	Connect to generator L1 (U) terminal. (Recommend 2 A fuse)

### 3.2.3 MAGNETIC PICK-UP AND DIGITAL INPUTS (3110-XXX-01)

**NOTE:** For further details of module configuration, refer to DSE Publication: *057-087 DSE3110 DSE Configuration Suite PC Software Manual.*

Pin No	Description	Cable Size	Notes
10	Magnetic Pickup Positive	0.5 mm <sup>2</sup> AWG 20	Connect To Magnetic Pickup Device
11	Magnetic Pickup Negative	0.5 mm <sup>2</sup> AWG 20	Connect To Magnetic Pickup Device
12	Configurable Digital Input A	0.5 mm <sup>2</sup> AWG 20	Switch to <i>DC Supply</i> Negative
13	Configurable Digital Input B	0.5 mm <sup>2</sup> AWG 20	Switch to <i>DC Supply</i> Negative
14	Configurable Digital Input C	0.5 mm <sup>2</sup> AWG 20	Switch to <i>DC Supply</i> Negative
15	Configurable Digital Input D	0.5 mm <sup>2</sup> AWG 20	Switch to <i>DC Supply</i> Negative
16	Configurable Digital Input E	0.5 mm <sup>2</sup> AWG 20	Switch to <i>DC Supply</i> Negative
17	Configurable Digital Input F	0.5 mm <sup>2</sup> AWG 20	Switch to <i>DC Supply</i> Negative

### 3.2.4 CAN AND DIGITAL INPUTS (3110-XXX-02)

**NOTE:** For further details of module configuration, refer to DSE Publication: *057-087 DSE3110 DSE Configuration Suite PC Software Manual.*

**NOTE:** For further details on connection to electronic engines, refer to DSE Publication: *057-004 Electronic Engines And DSE Wiring*

**NOTE:** Screened 120 Ω impedance cable specified for use with CAN must be used for the CAN link.  
DSE stock and supply Belden cable 9841 which is a high quality 120 Ω impedance cable suitable for CAN use (DSE part number 016-030)



Pin No	Description	Cable Size	Notes
10	CAN Port H	0.5 mm <sup>2</sup> AWG 20	Use only 120 Ω CAN approved cable
11	CAN Port L	0.5 mm <sup>2</sup> AWG 20	Use only 120 Ω CAN approved cable
12	Configurable Digital Input A	0.5 mm <sup>2</sup> AWG 20	Switch to <i>DC Supply</i> Negative
13	Configurable Digital Input B	0.5 mm <sup>2</sup> AWG 20	Switch to <i>DC Supply</i> Negative
14	Configurable Digital Input C	0.5 mm <sup>2</sup> AWG 20	Switch to <i>DC Supply</i> Negative
15	Configurable Digital Input D	0.5 mm <sup>2</sup> AWG 20	Switch to <i>DC Supply</i> Negative
16	Configurable Digital Input E	0.5 mm <sup>2</sup> AWG 20	Switch to <i>DC Supply</i> Negative
17	Configurable Digital Input F	0.5 mm <sup>2</sup> AWG 20	Switch to <i>DC Supply</i> Negative

### 3.2.5 PC CONFIGURATION INTERFACE CONNECTOR

**NOTE:** For further details of module configuration, refer to DSE Publication: *057-087 DSE3110 DSE Configuration Suite PC Software Manual*.

**NOTE:** The USB connection cable between the PC and the module must not be extended beyond 6 m (20 feet). For distances over 6 m, it is possible to use a third party USB extender. Typically, they extend USB up to 50 m (55 yards). The supply and support of this type of equipment is outside the scope of Deep Sea Electronics.

**CAUTION!** Care must be taken not to overload the PC's USB system by connecting more than the recommended number of USB devices to the PC. For further information, consult the PC supplier.

	Description	Cable Size	Notes
	Socket for connection to PC with DSE Configuration Suite Software	0.5 mm <sup>2</sup> AWG 20	This is a standard USB type A to type B connector. 



### 3.3 TYPICAL WIRING DIAGRAM

As every system has different requirements, these diagrams show only a typical system and do not intend to show a complete system.

Genset manufacturers and panel builders may use these diagrams as a starting point; however, refer to the completed system diagram provided by the system manufacturer for complete wiring detail.

Further wiring suggestions are available in the following DSE publications, available at [www.deepseaelectronics.com](http://www.deepseaelectronics.com)

DSE Part	Description
056-022	Switchgear Control
056-091	Equipotential Earth Bonding
056-092	Best Practices for Wiring Resistive Sensors
057-004	Electronic Engines and DSE Wiring

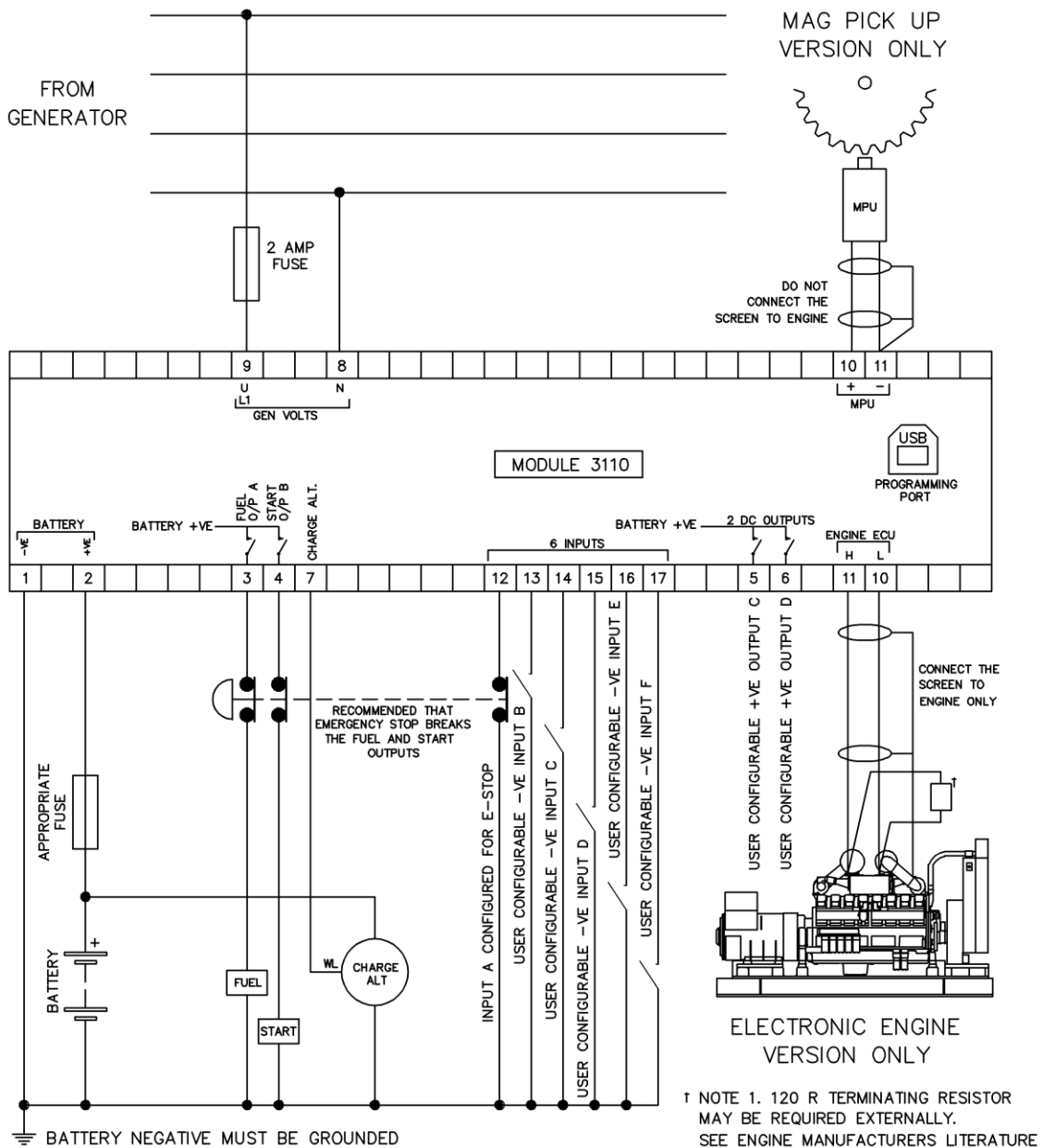

### **3.3.1 EARTH SYSTEMS**

#### **3.3.1.1 NEGATIVE EARTH**

The typical wiring diagrams located within this document show connections for a negative earth system (the battery negative connects to Earth)

#### **3.3.1.2 POSITIVE EARTH**

When using a DSE module with a Positive Earth System (the battery positive connects to Earth), the following points must be followed:

- Follow the typical wiring diagram as normal for all sections EXCEPT the earth points
- All points shown as Earth on the typical wiring diagram must connect to BATTERY NEGATIVE (not earth).

#### **3.3.1.3 FLOATING EARTH**



Where neither the battery positive nor battery negative terminals are connected to earth the following points must be followed

- Follow the typical wiring diagram as normal for all sections EXCEPT the earth points
- All points shown as Earth on the typical wiring diagram must connect to BATTERY NEGATIVE (not earth).

## 4 DESCRIPTION OF CONTROLS





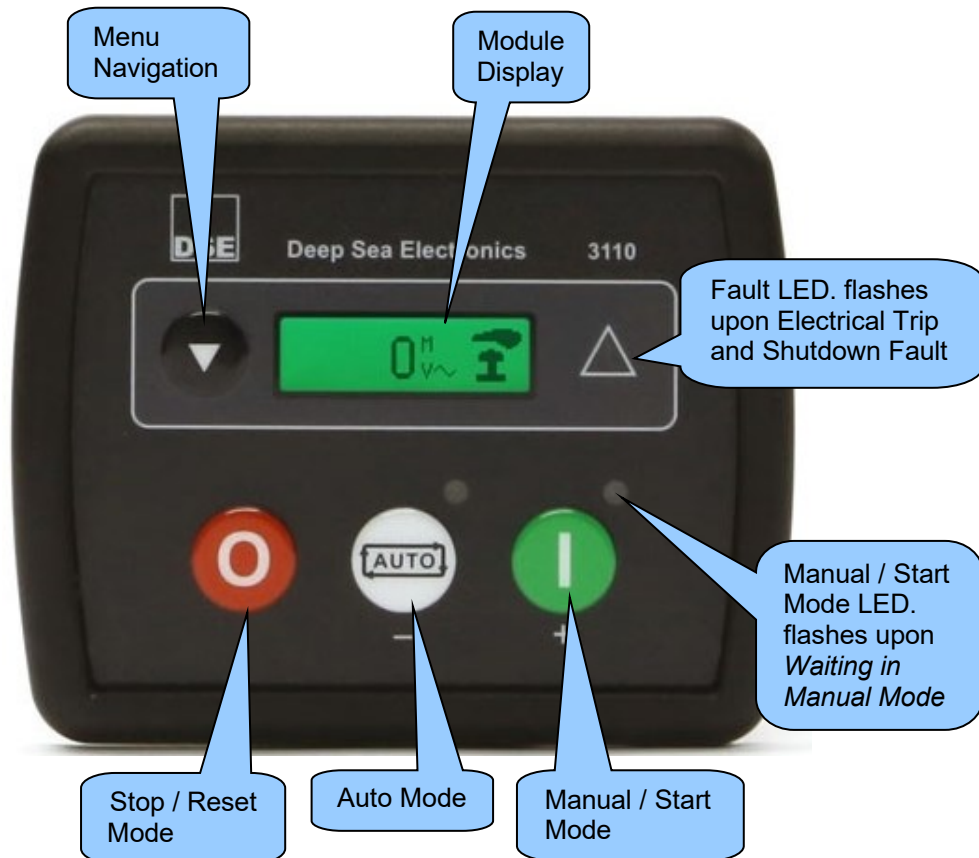

 **CAUTION:** The module may instruct an engine start event due to external influences. Therefore, it is possible for the engine to start at any time without warning. Prior to performing any maintenance on the system, it is recommended that steps are taken to remove the battery and isolate supplies.

 **NOTE:** The following descriptions detail the sequences followed by a module containing the standard 'factory configuration'. Always refer to the configuration source for the exact sequences and timers observed by any particular module in the field.

Control of the module is via push buttons mounted on the front of the module with *Stop/Reset Mode* , *Auto Mode*  and *Manual/Start Mode*  functions. For normal operation, these are the only controls which need to be operated. Details of their operation are provided later in this document.



## 4.1 CONTROL PUSH-BUTTONS

Icon	Description
	<p><b>Stop/Reset Mode</b></p> <p>This button places the module into its <i>Stop/Reset Mode</i> . This clears any alarm conditions for which the triggering criteria have been removed. If the engine is running and the module is put into Stop mode, the module automatically instructs the generator to unload (<i>Close Gen becomes inactive (if used)</i>). The fuel supply de-energises and the engine comes to a standstill. Should any form of remote start signal be present while operating in this mode, a start does <b>not</b> occur.</p>
	<p><b>Auto Mode</b></p> <p>This button places the module into its <i>Auto Mode</i> . This mode allows the module to control the function of the generator automatically. The module monitors the <i>Remote Start</i> input and battery charge status and once a start request is made, the set is automatically started and placed on load (<i>Close Gen becomes active (if used)</i>).</p> <p>Upon removal of the starting signal, the module removes the load from the generator and shut the set down observing the <i>Stop Delay</i> timer and <i>Cooling Down</i> timer as necessary (<i>Close Gen deactivates (if used)</i>). The module then awaits the next start event. For further details, see the more detailed section of <i>Operation</i> elsewhere in this manual.</p>
	<p><b>Manual/Start Mode</b></p> <p>This button starts the engine and runs it on load. For further details, see the more detailed section of <i>Operation</i> elsewhere in this manual.</p>
	<p><b>Menu Navigation</b></p> <p>Used for navigating the instrumentation, event log and configuration screens. For further details, see the more detailed section of <i>Operation</i> elsewhere in this manual.</p>

## 4.2 MODULE DISPLAY

The module's display contains the following sections. Description of each section are viewed in the sub sections.

Instrumentation Value	FPE No.	Icon
	Unit	

### Example of DSE3110 Display



### 4.2.1 BACKLIGHT

The LCD backlight is on if the unit has sufficient voltage while the unit is turned on, unless the unit is cranking for which the backlight is turned off.

### 4.2.2 ICON

#### 4.2.2.1 INOPERABLE ICONS

When the module is inoperable, a large icon is displayed which takes uses the entire display.

Icon	Description
	Appears when a configuration is being written to the module via the USB connection.
	Appears if either the configuration file or engine file becomes corrupted.

#### 4.2.2.2 MODE ICON

When there are no alarms present, a mode icon is displayed in the *Icon* section indicate the state the engine is in or operating mode of the module.

Icon	Details
	Appears when the engine is at rest and the unit is in stop mode with no alarms active.
	Appears when the engine is at rest and the unit is in auto mode with no alarms active.
	Appears when the engine is at rest and the unit is waiting for a manual start with no alarms active.
	Appears when a timer is active, for example cranking time, crank rest etc with no alarms active.
	Appears when the engine is running, and all timers have expired with no alarms active. The animation speed is reduced when running in idle mode.
	Appears when the unit is in the front panel editor.

#### 4.2.2.3 ALARM ICONS (PROTECTIONS)

When an alarm is active present, an alarm icon is displayed in the *Icon* section indicate the nature of the fault.

In the event of a warning alarm, the LCD only displays the *Alarm Icon*. In the event of an electrical trip or shutdown alarm, the module displays the *Alarm Icon* and the *Fault LED* begins to flash.

If multiple alarms are active at the same time, the *Alarm Icon* automatically cycles through all the appropriate icons to indicate each alarm which is active.

#### Example:

If the DSE controller was sensing a fail to stop alarm, generator under voltage alarm and a digital input alarm at the same time, it would cycle through all the icons to show this.

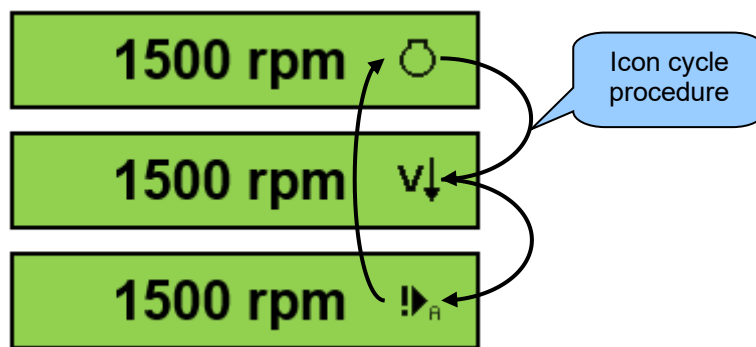

#### 4.2.2.3.1 WARNING ALARM ICONS

Warnings are non-critical alarm conditions and do not affect the operation of the generator system, they serve to draw the operators' attention to an undesirable condition.

Warning alarms are self-resetting when the fault condition is removed.

Icon	Fault	Description
	<b>User Configured Digital Inputs</b>	The module detects that a digital input (indicated by the letter) configured has active, generating a fault.
	<b>Fail To Stop</b>	<div style="border: 1px solid black; padding: 2px;"><b>NOTE: Fail to Stop could indicate a faulty oil pressure sensor. If engine is at rest check oil sensor wiring and configuration.</b></div> <p>The module has detected a condition that indicates that the engine is running when it has been instructed to stop.</p>
	<b>Charge Failure</b>	The auxiliary charge alternator voltage is low as measured from the W/L terminal.
	<b>CAN ECU Fault</b>	<div style="border: 1px solid black; padding: 2px;"><b>NOTE: Only applicable to 3110-xxx-02 CAN variant.</b></div> <p>The engine ECU has detected an alarm</p>
	<b>CAN Data Fail</b>	<div style="border: 1px solid black; padding: 2px;"><b>NOTE: Only applicable to 3110-xxx-02 CAN variant.</b></div> <p>The module does not detect data on the engine CAN data link.</p>

#### 4.2.2.3.2 ELECTRICAL TRIP ALARM ICONS

Electrical trips are latching and stop the Generator but in a controlled manner. On initiation of the electrical trip condition the module de-energise the *Close Gen* output to remove the load from the generator. Once this has occurred the module starts the Cooling timer and allows the engine to cool off-load before shutting down the engine. The alarm must be accepted and cleared, and the fault removed to reset the module.

Electrical trips are latching alarms and to remove the fault, press the *Stop/Reset Mode*  button on the module.

**NOTE: The alarm condition must be rectified before a resetting. If the alarm condition remains, it is not possible to reset the unit (The exception to this is the *Low Oil Pressure* alarm and similar *Active From Safety On* alarms, as the oil pressure is low with the engine at rest).**



















Icon	Fault	Description
	<b>User Configured Digital Inputs</b>	The module detects that a digital input (indicated by the letter) configured has active, generating a fault.

4.2.2.3.3 SHUTDOWN ALARM ICONS

Shutdown alarms are latching and immediately stop the Generator. On initiation of the shutdown condition the module de-energises the *Close Gen* output to remove the load from the generator. Once this has occurred, the module shuts the generator set down immediately to prevent further damage. The alarm must be accepted and cleared, and the fault removed to reset the module.

Shutdowns are latching alarms and to remove the fault, press the *Stop/Reset Mode*  button on the module.

 **NOTE: The alarm condition must be rectified before a resetting. If the alarm condition remains, it is not possible to reset the unit (The exception to this is the *Low Oil Pressure* alarm and similar *Active From Safety On* alarms, as the oil pressure is low with the engine at rest).**

Icon	Fault	Description
	<b>User Configured Digital Inputs</b>	The module detects that a digital input (indicated by the letter) configured has active, generating a fault.
	<b>Fail To Start</b>	The engine has failed to start after the configured number of start attempts
	<b>Low Oil Pressure</b>	The module detects that the engine oil pressure is low is after the <i>Safety On Timer</i> has expired.
	<b>High Coolant Temperature</b>	The module detects that the engine coolant temperature is high after the <i>Safety On Timer</i> has expired.
	<b>Under Speed</b>	The engine speed has fallen below the under speed alarm setting
	<b>Over Speed</b>	The engine speed has risen above the over speed alarm setting
	<b>Charge Failure</b>	The auxiliary charge alternator voltage is low as measured from the W/L terminal.
	<b>Low Fuel Level</b>	The module detects that the engine oil pressure is low.
	<b>Generator Under Voltage</b>	The generator output voltage has fallen below the under voltage alarm setting after the <i>Safety On Timer</i> has expired.
	<b>Generator Voltage</b>	The generator voltage has risen above the over voltage alarm setting.
	<b>Generator Under Frequency</b>	The generator output frequency has fallen below the under frequency alarm setting after the <i>Safety On Timer</i> has expired.
	<b>Generator Over Frequency</b>	The generator output frequency has risen above the over frequency alarm setting.
	<b>CAN ECU Fault</b>	<div style="border: 1px solid black; padding: 2px;"> <b>NOTE: Only applicable to 3110-xxx-02 CAN variant.</b></div> <p>The engine ECU has detected an alarm – CHECK ENGINE LIGHT Contact Engine Manufacturer for support.</p>
	<b>CAN Data Fail</b>	<div style="border: 1px solid black; padding: 2px;"> <b>NOTE: Only applicable to 3110-xxx-02 CAN variant.</b></div> <p>The module is does not detect data on the engine CAN data link.</p>
	<b>Emergency Stop</b>	The emergency stop button has been depressed. This failsafe (normally closed to emergency stop) input and immediately stops the set when the signal be removed.
	<b>Magnetic Pick-Up Failure</b>	<div style="border: 1px solid black; padding: 2px;"> <b>NOTE: Only applicable to 3110-xxx-01 MPU/Hz variant.</b></div> <p>Pulses are no longer being detected from the magnetic pickup probe</p>



### 4.2.3 VIEWING THE INSTRUMENT PAGES

It is possible to scroll through the display to view different pages of information by repeatedly operating the *Down*  navigation button.

Once selected, the *i* page remains on the LCD display until the user selects a different page.

**1500 rpm**  Engine Speed



Press the *Down*  navigation button...

**230 V**   Generator Voltage

Press the *Down*  navigation button...

**50 Hz**  Generator Frequency

Press the *Down*  navigation button...

**16.2**   Engine Hours

Press the *Down*  navigation button...

**13.8 V**   Battery Voltage

Press the *Down*  navigation button...

**6.7 bar**  Oil Pressure

 **NOTE: Only applicable to 3110-xxx-02 CAN variant.**

Press the *Down*  navigation button...

**86 °C**  Coolant Temperature

 **NOTE: Only applicable to 3110-xxx-02 CAN variant.**

## 5 OPERATION

**NOTE:** The following descriptions detail the sequences followed by a module containing the standard 'factory configuration'. Always refer to the configuration source for the exact sequences and timers observed by any particular module in the field.

### 5.1 QUICKSTART GUIDE

This section provides a quick start guide to the module's operation.

#### 5.1.1 STARTING THE ENGINE

**NOTE:** For further details, see the section entitled *Operation* elsewhere in this manual.



### 5.1.2 STOPPING THE ENGINE

**▲ NOTE:** For further details, see the section entitled *Operation* elsewhere in this manual.





## 5.2 STOP/RESET MODE

**NOTE:** If a digital input configured to *External Panel Lock* is active, changing module modes is not possible. Viewing the instruments is NOT affected by panel lock.

*Stop/Reset Mode* is activated by pressing the *Stop/Reset Mode*  button.

The *Stop/Reset*  icon is displayed to indicate *Stop/Reset Mode* operations.

In *Stop/Reset Mode* , the module removes the generator from load (*Close Gen deactivates immediately (if used and necessary)*) before stopping the engine if it is already running.

If the engine does not stop when requested, the *Fail To Stop*  alarm is activated (subject to the setting of the *Fail to Stop* timer). To detect the engine at rest the following must occur:

- Engine speed is zero
- Generator AC Voltage and Frequency must be zero.
- Engine Charge Alternator Voltage must be zero.
- Oil pressure switch or CAN message must indicate low oil pressure.

When the engine has stopped, it is possible to send configuration files to the module from DSE Configuration Suite PC software and to enter the Front Panel Editor to change parameters.

Any latched alarms are reset when *Stop/Reset Mode*  is entered if the fault is no longer active.

The engine is not started when in *Stop/Reset Mode* . If remote start signals are given, the input is ignored until *Auto Mode*  is entered.

**NOTE:** For further details of module configuration, refer to DSE Publication: *057-087 DSE3110 DSE Configuration Suite PC Software Manual*.

When the unit is configured for *Power Save Mode* and has been left in *Stop/Reset Mode*  with no presses of the fascia buttons, the module enters *Power Save Mode*. To 'wake' the module, press any fascia control buttons.

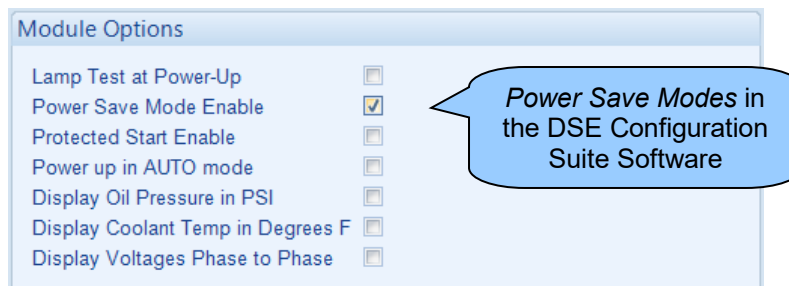

## 5.3 AUTOMATIC MODE

**NOTE:** If a digital input configured to *External Panel Lock* is active, changing module modes is not possible. Viewing the instruments is NOT affected by panel lock.

*Auto Mode* is activated by pressing the *Auto Mode*  button.

The *Auto Mode*  icon is displayed to indicate *Auto Mode* operations if no alarms are present.

Auto mode allows the generator to operate fully automatically, starting and stopping as required with no user intervention.

### 5.3.1 WAITING IN AUTO MODE

If a starting request is made, the starting sequence begins. Starting requests come from the following sources:

- Activation of an auxiliary input that has been configured to *Remote Start On/Off Load*.

### 5.3.2 STARTING SEQUENCE

To allow for 'false' start requests, the *Start Delay* timer begins.

When all start requests be removed during the *Start Delay* timer, the unit returns to a stand-by state.

If a start request is still present at the end of the *Start Delay* timer, the fuel relay is energised, and the engine is cranked.

**NOTE:** With the 3110-xxx-02 CAN variant, compatible ECU's receive the start command via CAN and transmit the engine speed to the DSE controller.

If the engine fails to fire during this cranking attempt then the starter motor is disengaged for the *Crank Rest* duration after which the next start attempt is made. If this sequence continues beyond the set number of attempts, the start sequence is terminated, and the display shows *Fail to Start* .

The starter motor is disengaged when the engine fires. Speed detection is factory configured to be derived from the AC alternator output frequency but can additionally be measured from a Magnetic Pickup mounted on the flywheel or from the CAN link to the engine ECU depending on module variant.

Additionally, rising oil pressure can be used disconnect the starter motor (but cannot detect under speed or over speed).

After the starter motor has disengaged, the *Safety On Delay* timer activates, allowing *Low Oil Pressure*, *High Engine Temperature*, *Underspeed* and any delayed *User Configured* digital inputs to stabilise without triggering the fault.

### 5.3.3 ENGINE RUNNING

 **NOTE: The *Close Gen* remain inactive until the *Oil Pressure* has risen. This prevents excessive wear on the engine.**

Once the engine is running and all starting timers have expired, the animated *Engine Running*  icon is displayed.

Once the generator is available, it is then placed on load (*Close Gen output becomes active (if used)*) if requested.

If all start requests are removed, the *Stopping Sequence* begins.

### 5.3.4 STOPPING SEQUENCE

The *Return Delay* timer operates to ensure that the starting request has been permanently removed and isn't just a short term removal. If another start request be made during the *Cooling Down* timer, the set returns on load.

If there are no starting requests at the end of the *Return Delay* timer, the load is removed from the generator (*Close Gen output deactivates (if used)*) and the *Cooling Down* timer is initiated.

The *Cooling Down* timer allows the set to run off load and cool sufficiently before being stopped. This is particularly important where turbo chargers are fitted to the engine.

After the *Cooling Down* timer has expired, the set is stopped.



## 5.4 MANUAL/START MODE

**NOTE:** If a digital input configured to *External Panel Lock* is active, changing module modes is not possible. Viewing the instruments is NOT affected by panel lock.

To begin the starting sequence, press the *Manual/Start Mode*  button. If *Protected Start* is disabled, the start sequence begins immediately.

### 5.4.1 WAITING IN MANUAL MODE

**NOTE:** For further details of module configuration, refer to DSE Publication: *057-087 DSE3110 DSE Configuration Suite PC Software Manual*.

If *Protected Start* is enabled, the *Waiting in Manual Mode*  icon is displayed and the LED above the *Manual/Start Mode*  button flashes to indicate *Waiting in Manual Mode*.

The *Manual/Start Mode*  button must be pressed once more to begin the start sequence.

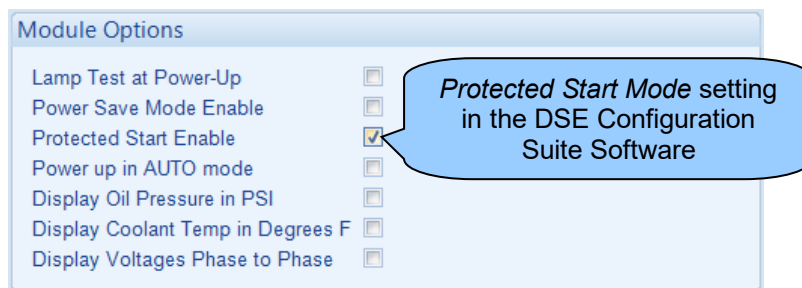

### 5.4.2 STARTING SEQUENCE

 **NOTE: There is no *Start Delay* in this mode of operation.**

The fuel relay is energised, and the engine is cranked.

 **NOTE: With the 3110-xxx-02 CAN variant, compatible ECU's receive the start command via CAN and transmit the engine speed to the DSE controller.**

If the engine fails to fire during this cranking attempt then the starter motor is disengaged for the *Crank Rest* duration after which the next start attempt is made. If this sequence continues beyond the set number of attempts, the start sequence is terminated, and the display shows *Fail to Start* .

The starter motor is disengaged when the engine fires. Speed detection is factory configured to be derived from the AC alternator output frequency but can additionally be measured from a Magnetic Pickup mounted on the flywheel or from the CAN link to the engine ECU depending on module variant.

Additionally, rising oil pressure can be used disconnect the starter motor (but cannot detect under speed or over speed).

After the starter motor has disengaged, the *Safety On Delay* timer activates, allowing *Low Oil Pressure*, *High Engine Temperature*, *Underspeed* and any delayed *User Configured* digital inputs to stabilise without triggering the fault.



### 5.4.3 ENGINE RUNNING

 **NOTE: For further details of module configuration, refer to DSE Publication: 057-087 DSE3110 DSE Configuration Suite PC Software Manual.**

Once the engine is running and all starting timers have expired, the animated *Engine Running*  icon is displayed.

Once the generator is available, it is then placed on load (*Close Gen output becomes active (if used)*).



Once the generator has been placed on load, it is not automatically removed. To manually remove the load either:

- Press the *Auto Mode*  button to return to automatic mode. The set observes all *Auto Mode*  start requests and stopping timers before beginning the *Auto Mode Stopping Sequence*.
- Press the *Stop/Reset Mode*  button to remove load and stop the generator.



#### 5.4.4 STOPPING SEQUENCE

In *Manual/Start Mode*  the set continues to run until either:

- The *Stop/Reset Mode*  button is pressed – The *Close Gen* output is de-activated immediately and the set immediately stops.
- The *Auto Mode*  button is pressed. The set observes all *Auto Mode*  start requests and stopping timers before beginning the *Auto Mode Stopping Sequence*.

#### 5.5 ALTERNATIVE CONFIGURATIONS

Depending upon the configuration of the system by the generator supplier, the system may have selectable configurations (for example to select between 50 Hz and 60 Hz). If this has been enabled the generator supplier is to advise how this selection is to be made (usually by operating an external selector switch or by selecting the required configuration file in the module's front panel configuration editor).

## 6 FRONT PANEL CONFIGURATION

**NOTE:** Depending upon module configuration, some values in the *Front Panel Configuration Editors* may not be available. For further details of module configuration, refer to DSE Publication: 057-087 *DSE3110 DSE Configuration Suite PC Software Manual*.

This configuration mode allows the operator to fully configure the module through its display without the use of the DSE Configuration Suite PC Software.

Use the module's facia buttons to traverse the menu and make value changes to the parameters:

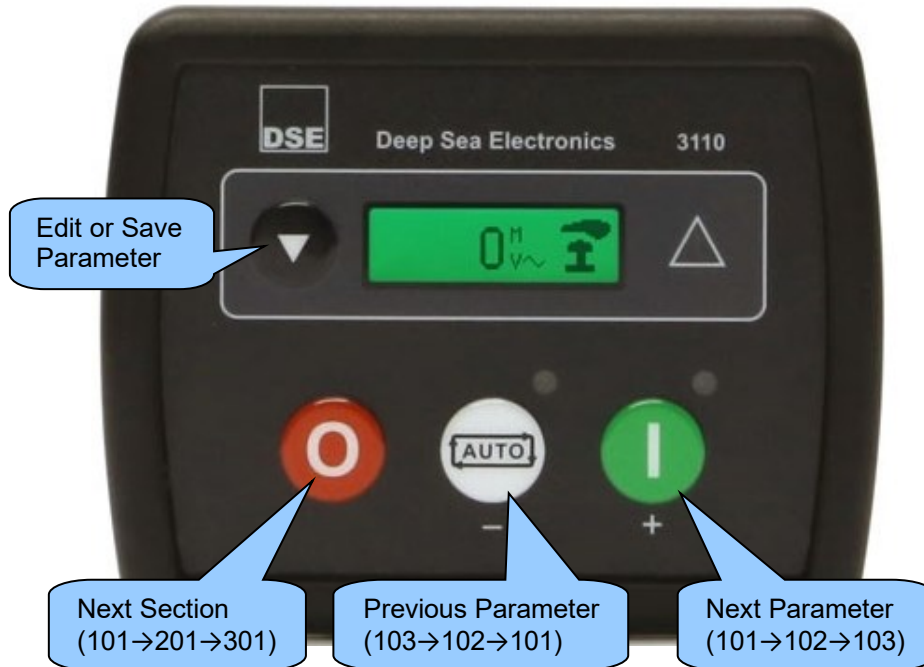

## 6.1 ACCESSING & OPERATING THE FRONT PANEL EDITORS







 **NOTE:** For further details of module configuration, refer to DSE Publication: 057-087 *DSE3110 DSE Configuration Suite PC Software Manual*.

### 6.1.1 ENTERING THE EDITORS

- Press the *Stop/Reset Mode*  and *Navigation*  buttons together to enter the editor  mode.



### 6.1.2 EDITING A PARAMETER

 **NOTE:** Pressing and holding the *Manual/Start Mode*  (+) or *Auto Mode*  (-) buttons will give auto-repeat functionality.

- Press the *Stop/Reset Mode*  button to select the required page.
- Press the *Manual/Start Mode*  (+) button to cycle to the next parameter, or the *Auto Mode*  (-) buttons to cycle to the previous parameter, within the current page.
- When viewing the parameter to be edited, press the *Navigation*  button and the value begins to flash.
- Press the *Manual/Start Mode*  (+) or *Auto Mode*  (-) buttons to adjust the value to the required setting.
- Press the *Navigation*  button the save the current value, the value ceases flashing.

### 6.1.3 EXITING THE EDITORS

 **NOTE:** The editor automatically exits after 5 minutes of inactivity to ensure security.

- Press and hold the *Navigation*  button to exit the editor, the configuration icon  is removed from the display

## 6.2 ADJUSTABLE PARAMETERS IN CONFIGURATION EDITOR

### 6.2.1 MODULE SETTINGS

MPU/Hz	3110-xxx-01 (MPU/Hz) option only
CAN	3110-xxx-02 (CAN) option only

Configuration Parameters – Module (Page 1)			
101	Contrast	000 %	
102	RESERVED		
103	RESERVED		
104	Lamp Test at Start-up	On (1), Off (0)	
105	Power Save Mode Enable	On (1), Off (0)	
106	Protected Start Enabled	On (1), Off (0)	
107	Power Up in Auto Mode	On (1), Off (0)	
108	Oil Pressure Display	PSI (1), Bar (0)	CAN
109	Display Volts in Ph-Ph	On (1), Off (0)	
110	Temperature Display	°F (1), °C (0)	CAN

### 6.2.2 CAN SETTINGS

MPU/Hz	3110-xxx-01 (MPU/Hz) option only
CAN	3110-xxx-02 (CAN) option only

Configuration Parameters – Application (Page 2)			
201	Default Configuration	On (1), Off (0)	CAN
202	Alternative Engine Speed	On (1), Off (0)	CAN
203	CAN ECU Data Fail Arming	0 (Arming)	CAN
204	CAN ECU Data Fail Action	0 (Action)	CAN
205	CAN ECU Data Fail Delay	0 s	CAN

### 6.2.3 DIGITAL INPUT SETTINGS

MPU/Hz	3110-xxx-01 (MPU/Hz) option only
CAN	3110-xxx-02 (CAN) option only

<b>Configuration Parameters – Digital Inputs (Page 3)</b>			
301	Low Oil Pressure Enable	On (1), Off (0)	CAN
302	Low Oil Pressure Trip	0.00 Bar / PSI	CAN
303	High Engine Temperature Trip	0 °C / °F	CAN
304	Digital Input A Source	0 (Input Source)	
305	Digital Input A Polarity	0 (Polarity)	
306	Digital Input A Action (If Source = User Config)	0 (Action)	
307	Digital Input A Arming (If Source = User Config)	0 (Arming)	
308	RESERVED		
309	Digital Input B Source	0 (Input Source)	
310	Digital Input B Polarity	0 (Polarity)	
311	Digital Input B Action (If Source = User Config)	0 (Action)	
312	Digital Input B Arming (If Source = User Config)	0 (Arming)	
313	RESERVED		
314	Digital Input C Source	0 (Input Source)	
315	Digital Input C Polarity	0 (Polarity)	
316	Digital Input C Action (If Source = User Config)	0 (Action)	
317	Digital Input C Arming (If Source = User Config)	0 (Arming)	
318	RESERVED	0:00	
319	Digital Input D Source	0 (Input Source)	
320	Digital Input D Polarity	0 (Polarity)	
321	Digital Input D Action (If Source = User Config)	0 (Action)	
322	Digital Input D Arming (If Source = User Config)	0 (Arming)	
323	RESERVED	0:00	
324	Digital Input E Source	0 (Input Source)	
325	Digital Input E Polarity	0 (Polarity)	
326	Digital Input E Action (If Source = User Config)	0 (Action)	
327	Digital Input E Arming (If Source = User Config)	0 (Arming)	
328	RESERVED	0:00	
329	Digital Input F Source	0 (Input Source)	
330	Digital Input F Polarity	0 (Polarity)	
331	Digital Input F Action (If Source = User Config)	0 (Action)	
332	Digital Input F Arming (If Source = User Config)	0 (Arming)	

### 6.2.4 OUTPUT SETTINGS

MPU/Hz	3110-xxx-01 (MPU/Hz) option only
CAN	3110-xxx-02 (CAN) option only

<b>Configuration Parameters – Outputs (Page 4)</b>			
401	Digital Output A Source	0 (Output Source)	CAN
402	Digital Output A Polarity	0 (Output Polarity)	CAN
403	Digital Output B Source	0 (Output Source)	CAN
404	Digital Output B Polarity	0 (Output Polarity)	CAN
405	Digital Output C Source	0 (Output Source)	
406	Digital Output C Polarity	0 (Output Polarity)	
407	Digital Output D Source	0 (Output Source)	
408	Digital Output D Polarity	0 (Output Polarity)	

**6.2.5 TIMER SETTINGS**

<b>Configuration Parameters – Timers (Page 5)</b>	
501	Remote Start Delay
502	Preheat Timer
503	RESERVED
504	RESERVED
505	Smoke Limiting
506	Smoke Limiting Off
507	RESERVED
508	Warm Up Time
509	Return Delay
510	Cooling Time
511	ETS Solenoid Hold
512	RESERVED
513	RESERVED
514	RESERVED
515	Breaker Trip Pulse
516	Breaker Close Pulse

**6.2.6 GENERATOR SETTINGS**

<b>Configuration Parameters – Generator (Page 6)</b>		
601	Alternator Fitted	On (1), Off (0)
602	Alternator Poles	0
603	RESERVED	
604	RESERVED	
605	Under Voltage Shutdown Enabled	On (1), Off (0)
606	Under Voltage Trip Shutdown	0 V
607	Loading Voltage	0 V
608	Over Voltage Shutdown Trip	0 V
609	Under Frequency Shutdown Enable	On (1), Off (0)
610	Under Frequency Shutdown Trip	0.0 Hz
611	Loading Frequency	0.0 Hz
612	Nominal Frequency	0.0 Hz
613	Over Frequency Shutdown Enable	On (1), Off (0)
614	Over Frequency Shutdown Trip	0.0 Hz
615	AC System	0-4

### 6.2.7 ENGINE SETTINGS

MPU/Hz	3110-xxx-01 (MPU/Hz) option only
CAN	3110-xxx-02 (CAN) option only

Configuration Parameters – Engine (Page 7)			
701	Magnetic Pickup Fitted	On (1), Off (0)	MPU/Hz
702	Flywheel Teeth	000	MPU/Hz
703	Start Attempts	0	
704	RESERVED		
705	RESERVED		MPU/Hz
706	Gas Choke Timer (Gas Engine Only)	0:00	MPU/Hz
707	Gas On Delay (Gas Engine Only)	0:00	MPU/Hz
708	Gas Ignition Off Delay (Gas Engine Only)	0:00	
709	Crank Disconnect on Oil Enable	On (1), Off (0)	
710	Check Oil Pressure Prior to Starting	On (1), Off (0)	
711	Crank Disconnect on Oil Threshold	0.00 Bar	CAN
712	Crank Disconnect on Frequency	0.0 Hz	
713	Crank Disconnect on Engine Speed	000 rpm	
714	Under Speed Enable	On (1), Off (0)	
715	Under Speed Trip	0000 rpm	
716	Over Speed Trip	0000 rpm	
717	RESERVED		
718	RESERVED		
719	RESERVED		
720	RESERVED		
721	RESERVED		
722	RESERVED		
723	RESERVED		
724	RESERVED		
725	Charge Alt Failure Enable	On (1), Off (0)	
726	Charge Alt Failure Trip	0.0 V	

### 6.2.8 ALTERNATE CONFIGURATION SETTINGS

Configuration Parameters – Alternate Configuration (Page 8)		
801	Enable Configuration	On (1), Off (0)
802	Alternative Engine Speed	On (1), Off (0)
803	Under Voltage Shutdown Enable	On (1), Off (0)
804	Under Voltage Trip	On (1), Off (0)
805	Under Voltage Trip Level	0 V
806	Loading Voltage	0 V
807	Over Voltage Trip Level	0 V
808	Under Frequency Enabled	On (1), Off (0)
809	Under Frequency Trip level	0.0 Hz
810	Loading Frequency	0.0 Hz
811	Nominal Frequency	0.0 Hz
812	Over Frequency Enabled	On (1), Off (0)
813	Over Frequency Trip Level	0.0 Hz
814	Alternative Under Speed Enable	On (1), Off (0)
815	Alternative Under Speed Trip	0000 rpm
816	Alternative Over Speed Trip	0000 rpm

## 6.3 SELECTABLE PARAMETER SETTINGS

### 6.3.1 OUTPUT SOURCES

MPU/Hz	3110-xxx-01 (MPU/Hz) option only
CAN	3110-xxx-02 (CAN) option only

Output Sources		
1	Not Used	
2	RESERVED	
3	RESERVED	
4	RESERVED	
5	RESERVED	
6	RESERVED	
7	CAN ECU Data Fail	CAN
8	CAN ECU Error	CAN
9	CAN ECU Fail	CAN
10	CAN ECU Power	CAN
11	CAN ECU Stop	CAN
12	RESERVED	
13	Close Gen Output	
14	Close Gen Output Pulse	
15	Common Alarm	
16	Common Shutdown	
17	Common Warning	
18	RESERVED	
19	RESERVED	
20	RESERVED	
21	RESERVED	
22	RESERVED	
23	RESERVED	
24	RESERVED	
25	RESERVED	
26	Energise to Stop	
27	RESERVED	
28	RESERVED	
29	Fuel Relay	
30	Gas Choke On	MPU/Hz
31	Gas Ignition	MPU/Hz
32	RESERVED	
34	RESERVED	
35	RESERVED	
36	RESERVED	
37	RESERVED	
38	RESERVED	
39	RESERVED	
40	Open Gen Output	
41	Open Gen Output Pulse	
42	Plant Battery Over Voltage Warning	
43	Plant Battery Under Voltage Warning	
44	Preheat During Preheat Timer	
45	Preheat Until End of Crank	
46	Preheat Until End of Safety Timer	
47	Preheat Until End of Warming Timer	
48	Smoke Limiting	
49	Start Relay	



### 6.3.2 INPUT SOURCES

Input Source	
0	User Configured
1	RESERVED Alarm Mute
2	RESERVED Alarm Reset
3	Alternative Configuration
4	Coolant Temperature Switch
5	Emergency Stop
6	External Panel Lock
7	RESERVED Generator Closed Auxiliary
8	RESERVED Lamp Test
9	Low Fuel Level Switch
10	Oil Pressure Switch
11	Remote Start Off Load
12	Remote Start On Load
13	Smoke Limiting

### 6.3.3 AC TOPOLOGY

AC System		
Index	Type	Instrumentation
0	Single Phase 2 Wire	L-N
1	2 Phase 3 Wire (L1 to L2 or L1 to L3)	L-N x 2
2	3 Phase 4 Wire	L-N x $\sqrt{3}$
3	3 Phase 3 Wire	L-N
4	3 Phase 4 Wire (Delta)	L-N x 2

### 6.3.4 ALARM ACTION

Alarm Action	
Index	Action
0	Electrical Trip
1	Shutdown
2	Warning

### 6.3.5 DIGITAL INPUT ALARM ARMING

Digital Input Alarm Arming	
Index	Arming
0	Always
1	From Safety On
2	From Starting
3	Never

### 6.3.6 DIGITAL INPUT POLARITY

Digital Input Polarity	
Index	Polarity
0	Close to Activate
1	Open to Activate

### 6.3.7 DIGITAL OUTPUT POLARITY

<b>Output Polarity</b>	
<b>Index</b>	<b>Polarity</b>
0	Energise
1	De-Energise

### 6.3.8 CAN DATA FAIL ALARM ACTION

<b>CAN Data Fail Action</b>	
<b>Index</b>	<b>Type</b>
0	None
1	Shutdown
2	Latched Warning

### 6.3.9 CAN DATA FAIL ALARM ARMING





<b>CAN Data Fail Arming</b>	
<b>Index</b>	<b>Arming</b>
0	From Safety On
1	From Starting

## 7 COMMISSIONING

Before the system is started, it is recommended that the following checks are made:-

- The unit is adequately cooled and all the wiring to the module is of a standard and rating compatible with the system. Check all mechanical parts are fitted correctly and that all electrical connections (including earths) are sound.
- The unit **DC** supply is fused and connected to the battery and that it is of the correct polarity.



 **NOTE: If Emergency Stop feature is not required, link this input to the DC Negative or disable the input. For further details of module configuration, refer to DSE Publication: 057-087 DSE3110 DSE Configuration Suite PC Software Manual.**

- The Emergency Stop input is wired to an external **normally closed** switch connected to **DC negative**.
- To check the start cycle operation, take appropriate measures to prevent the engine from starting (disable the operation of the fuel solenoid). After a visual inspection to ensure it is safe to proceed, connect the battery supply. Press the *Manual/Start Mode*  button the unit start sequence commences.
- The starter engages and operates for the pre-set crank period. After the starter motor has attempted to start the engine for the pre-set number of attempts, the LCD displays *Fail to Start* . Press the *Stop/Reset Mode*  button to reset the unit.
- Restore the engine to operational status (reconnect the fuel solenoid). Press the *Manual/Start Mode*  button. This time the engine starts, and the starter motor disengages automatically. If not then check that the engine is fully operational (fuel available, etc.) and that the fuel solenoid is operating. The engine now runs up to operating speed. If not, and an alarm is present, check the alarm condition for validity, then check input wiring. The engine continues to run for an indefinite period. It is possible currently to view the engine and alternator parameters.
- Press the *Auto Mode*  button, the engine runs for the pre-set cooling down period, then stop. The generator stays in the standby mode. If not check that there is not a signal present on the *Remote Start* input.
- Initiate an automatic start by supplying the remote start signal (if configured). The start sequence commences, and the engine runs up to operational speed. Once the generator is available the *Close Gen* output (if configured) activates. If not, check the wiring to the generator contactors. Check the *Warming Up* timer has timed out.
- Remove the remote start signal. The return sequence begins. After the pre-set time, the generator is unloaded. The generator then runs for the pre-set *Cooling Down* timer, then shutdown into its standby mode.
- If, despite repeated checking of the connections between the controller and the customer's system, satisfactory operation cannot be achieved, then the customer is requested to the DSE Technical Support Department

## 8 FAULT FINDING

**NOTE:** The below fault finding is provided as a guide check-list only. As the module can be configured to provide a wide range of different features, always refer to the source of the module configuration if in doubt.





### 8.1 STARTING

Symptom	Possible Remedy
Unit is inoperative  Read/Write configuration does not operate	Check the battery and wiring to the unit. Check the DC supply. Check the DC fuse.
Unit shuts down	Check DC supply voltage is not above 35 Volts or below 9 Volts Check the operating temperature is not above 70°C. Check the DC fuse.
<i>Fail to Start</i>  is activated after pre-set number of attempts to start	Check wiring of fuel solenoid. Check fuel. Check battery supply. Check battery supply is present on the Fuel output of the module. Check the speed-sensing signal is present on the module's inputs. Refer to engine manual.
Continuous starting of generator when in the <i>Auto Mode</i> 	Check that there is no signal present on the "Remote Start" input. Check configured polarity is correct.
Generator fails to start on receipt of Remote Start signal.	Check Start Delay timer has timed out.  Check signal is on "Remote Start" input. Confirm correct configuration of input is configured to be used as "Remote Start".  Check that the oil pressure switch or sensor is indicating low oil pressure to the controller. Depending upon configuration, the set does not start if oil pressure is not low.
Pre-heat inoperative	Check wiring to engine heater plugs. Check battery supply. Check battery supply is present on the Pre-heat output of module. Check pre-heat configuration is correct.
Starter motor inoperative	Check wiring to starter solenoid. Check battery supply. Check battery supply is present on the Starter output of module. Ensure oil pressure switch or sensor is indicating the "low oil pressure" state to the controller.

### 8.2 LOADING

Symptom	Possible Remedy
Engine runs but generator does not take load	Check Warm up timer has timed out. Ensure generator load inhibit signal is not present on the module inputs. Check connections to the switching device.
Incorrect reading on engine gauges  <i>Fail To Stop</i>  when engine is at rest	Check engine is operating correctly.  Check that sensor is compatible with the module and that the module configuration is suited to the sensor.

### 8.3 ALARMS

Symptom	Possible Remedy
Low Oil Pressure  operates after engine has fired	Check engine oil pressure. Check oil pressure switch/sensor and wiring. Check configured polarity (if applicable) is correct (i.e. Normally Open or Normally Closed) or that sensor is compatible with the module and is correctly configured.
High Coolant Temperature  operates after engine has fired.	Check engine temperature. Check switch/sensor and wiring. Check configured polarity (if applicable) is correct (i.e. Normally Open or Normally Closed) or that sensor is compatible with the module.
Shutdown fault operates	Check relevant switch and wiring of fault indicated on LCD display. Check configuration of input.
Electrical Trip fault operates	Check relevant switch and wiring of fault indicated on LCD display. Check configuration of input.
Warning fault operates	Check relevant switch and wiring of fault indicated on LCD display. Check configuration of input.
CAN ECU Fault 	This indicates a fault condition detected by the engine ECU and transmitted to the DSE controller.
CAN Data Fail 	Indicates failure of the CAN data link to the engine ECU. Check all wiring and termination resistors (if required).
Incorrect reading on Engine gauges	Check engine is operating correctly. Check sensor and wiring paying attention to the wiring to terminal 10.
Fail To Stop  when engine is at rest	Check that sensor is compatible with the module and that the module configuration is suited to the sensor.

### 8.4 COMMUNICATIONS

Symptom	Possible Remedy
CAN Data Fail 	Indicates failure of the CAN data link to the engine ECU. Check all wiring and termination resistors (if required).

### 8.5 MISCELLANEOUS

Symptom	Possible Remedy
Module appears to 'revert' to an earlier configuration	<p>When editing a configuration using the PC software it is vital that the configuration is first 'read' from the controller before editing it. This edited configuration must then be "written" back to the controller for the changes to take effect.</p> <p>When editing a configuration using the fascia editor, be sure to press the <i>Navigation</i>  button to save the change before moving to another item or exiting the fascia editor</p>

## 9 MAINTENANCE, SPARES, REPAIR AND SERVICING

The controller is *Fit and Forget*. As such, there are no user serviceable parts within the controller. In the case of malfunction, contact the original equipment manufacturer (OEM).

### 9.1 PURCHASING ADDITIONAL CONNECTOR PLUGS FROM DSE

If additional plugs are required from DSE, contact our Sales department using the part numbers below.

#### 9.1.1 PACK OF PLUGS

Module Type	Plug Pack Part Number
DSE3110	007-515

#### 9.1.2 INDIVIDUAL PLUGS

Module Terminal Number	Plug Description	Part No.
1 to 7	7 way 5.08 mm	007-447
8 to 9	2 way 7.62 mm	007-448
10 to 17	8 way 5.08 mm	007-164
 USB	PC Configuration interface lead (USB type A – USB type B)	016-125

### 9.2 PURCHASING ADDITIONAL FIXING CLIPS FROM DSE

Item	Description	Part No.
	Module Fixing Clips (Packet Of 2)	020-406

### 9.3 PURCHASING OPTIONAL SEALING GASKET FROM DSE

Item	Description	Part No.
	Module Silicon Sealing Gasket	020-385

## 10 WARRANTY

DSE provides limited warranty to the equipment purchaser at the point of sale. For full details of any applicable warranty, refer to the original equipment supplier (OEM).

## 11 DISPOSAL

### 11.1 WEEE (WASTE ELECTRICAL AND ELECTRONIC EQUIPMENT)

If electrical and electronic equipment is used, it must be stored, collected, treated, recycled and disposed of WEEE separately from other waste.



*This Page is Intentionally Blank*